



US006255396B1

(12) **United States Patent**  
**Ding et al.**(10) **Patent No.:** **US 6,255,396 B1**  
(45) **Date of Patent:** **Jul. 3, 2001**(54) **CYCLOOLEFIN BLENDS AND METHOD FOR SOLVENT BONDING POLYOLEFINS**(75) Inventors: **Yuan-pang Samuel Ding**, Vernon Hills; **Chuan Qin**, Gurnee; **Lecon Woo**, Libertyville; **Michael T. K. Ling**; **Sherwin Shang**, both of Vernon Hills; **Tahua Yang**, Darien, all of IL (US)(73) Assignee: **Baxter International Inc.**, Deerfield, MI (US)

(\*) Notice: Subject to any disclaimer, the term of this patent is extended or adjusted under 35 U.S.C. 154(b) by 0 days.

5,650,471	7/1997	Abe et al. .
5,693,728	12/1997	Okamoto et al. .
5,698,654	12/1997	Weller et al. .
5,723,189	3/1998	Sudo .
5,733,991	3/1998	Rohrmann et al. .
5,744,664	4/1998	Brekner et al. .
5,788,670	8/1998	Reinhard et al. .
5,792,824	8/1998	Natori .
5,795,945	8/1998	Natori .
5,854,349	12/1998	Abe et al. .
5,863,986	1/1999	Herrmann-Schönherr et al. .
5,980,495	11/1999	Heinz et al. .
6,007,520	12/1999	Sudo .
6,065,270	5/2000	Reinhard et al. .
6,068,936	5/2000	Peiffer et al. .

## FOREIGN PATENT DOCUMENTS

(21) Appl. No.: **09/392,912**

(22) Filed: **Sep. 9, 1999**

(51) **Int. Cl.**<sup>7</sup> ..... **C08F 8/00**; C08L 23/00;  
C08L 23/04; C08L 45/00

(52) **U.S. Cl.** ..... **525/191**; 525/210; 525/211;  
525/240

(58) **Field of Search** ..... 525/191, 210,  
525/211, 240

133411	1/1979	(DE) .
251 904 A3	12/1987	(DE) .
39 37 865 A1	6/1990	(DE) .
0 156 464 A1	10/1985	(EP) .
0 216 509 B1	8/1986	(EP) .
0 283 164	3/1988	(EP) .
0 291 208	4/1988	(EP) .
0 291 208 A2	11/1988	(EP) .
0 492 982 B1	12/1991	(EP) .
0 497 567 A2	1/1992	(EP) .
92306664	7/1992	(EP) .
0 524 802 A1	1/1993	(EP) .
0 582 355 B1	2/1994	(EP) .
0 680 401 B1	11/1995	(EP) .
0 430 585 B1	1/1996	(EP) .
0 156 464 B1	5/1996	(EP) .
0 709 105 A1	5/1996	(EP) .
0 203 799 B1	8/1996	(EP) .
0 384 694 B1	9/1996	(EP) .
0 497 567 B1	9/1996	(EP) .
0 790 063 A1	8/1997	(EP) .
97/08054	6/1997	(WO) .
98/27926	2/1998	(WO) .

(56) **References Cited**

## U.S. PATENT DOCUMENTS

3,494,897	2/1970	Reding et al. .
4,573,994	3/1986	Fischell et al. .
4,628,969	12/1986	Jurgens, Jr. et al. .
4,992,511	2/1991	Yamamoto et al. .
5,003,019	3/1991	Ishimaru et al. .
5,008,356	4/1991	Ishimaru et al. .
5,087,677	2/1992	Brekner et al. .
5,207,983	5/1993	Liebert et al. .
5,218,049	6/1993	Yamamoto et al. .
5,272,235	12/1993	Wakatsuru et al. .
5,288,560	2/1994	Sudo et al. .
5,331,057	7/1994	Brekner et al. .
5,359,001	10/1994	Epple et al. .
5,422,409	6/1995	Brekner et al. .
5,457,249	10/1995	Toshihiro et al. .
5,475,060	12/1995	Brekner et al. .
5,498,677	3/1996	Wellner et al. .
5,534,606	7/1996	Bennett et al. .
5,552,504	9/1996	Bennett et al. .
5,583,192	12/1996	Bennett et al. .
5,610,253	3/1997	Hatke et al. .
5,620,425	4/1997	Heffernan et al. .
5,629,398	5/1997	Okamoto et al. .
5,637,100	6/1997	Sudo .
5,637,400	6/1997	Brekner et al. .

*Primary Examiner*—Nathan M. Nutter(74) *Attorney, Agent, or Firm*—Mark J. Buonaiuto; Joseph A. Fuchs(57) **ABSTRACT**

The present invention provides a polymer composition having a first component obtained by copolymerizing a norbornene monomer and an ethylene monomer, the first component being in an amount from about 1–99% by weight of the composition; and a second component of an ethylene and  $\alpha$ -olefin copolymer, the  $\alpha$ -olefin having 6 carbons, the second component being in an amount from about 99% to about 1% by weight of the composition.

**21 Claims, 1 Drawing Sheet**

FIG. 1

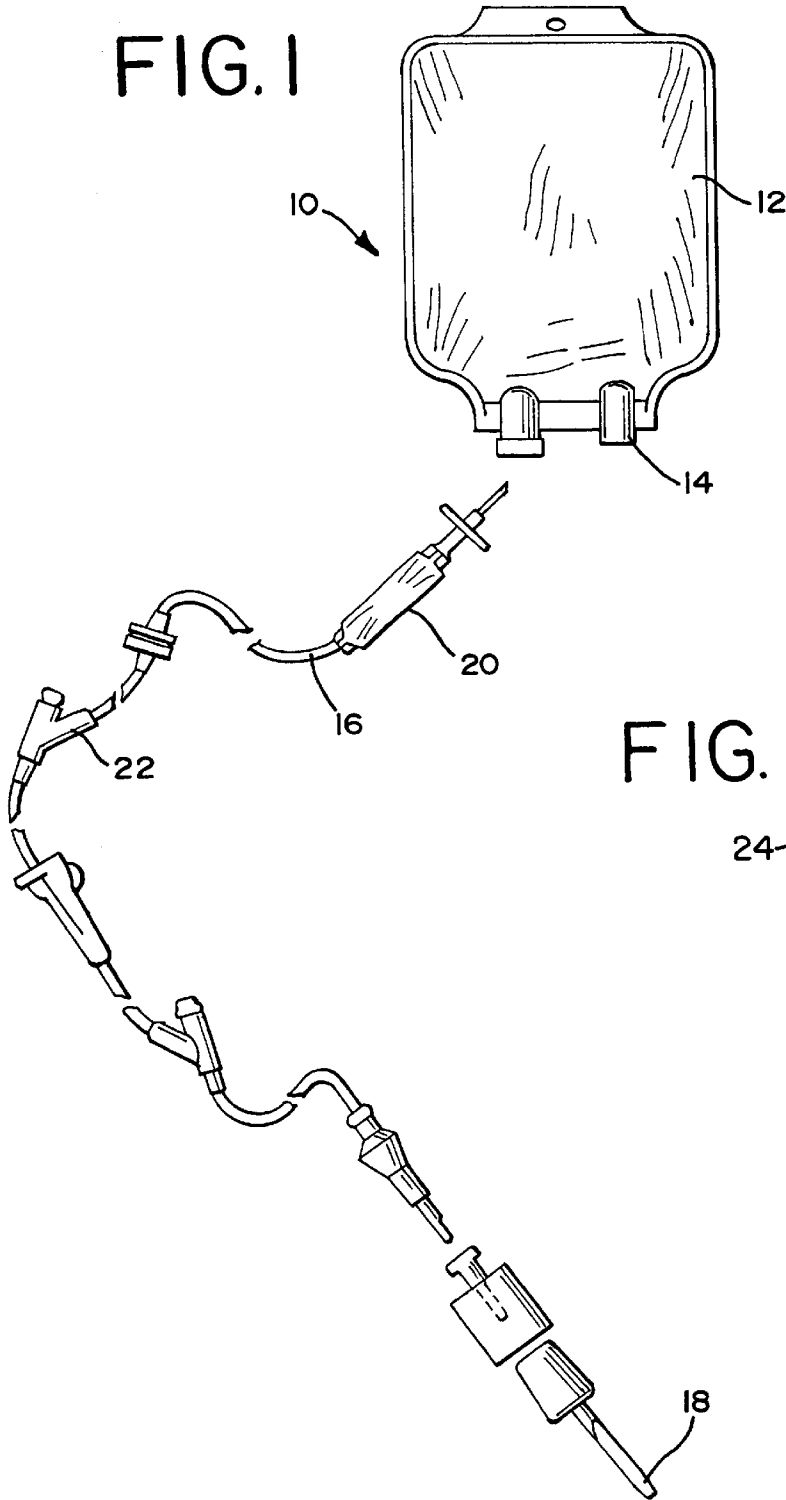
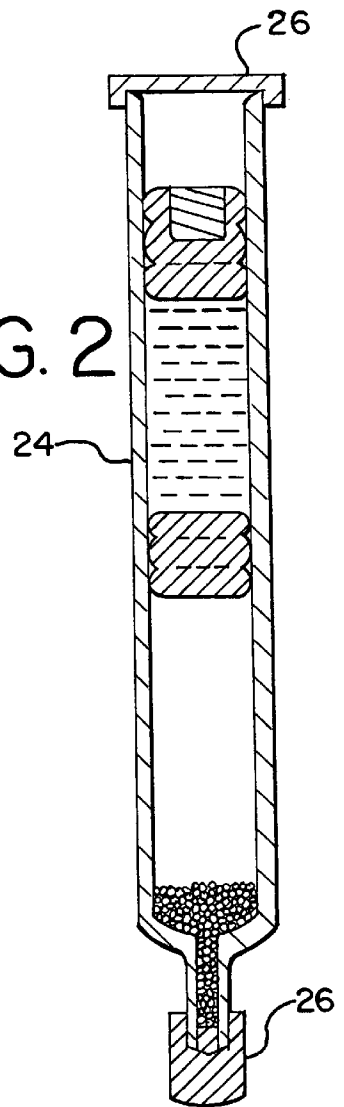

FIG. 2



## CYCLOOLEFIN BLENDS AND METHOD FOR SOLVENT BONDING POLYOLEFINS

### TECHNICAL FIELD

This invention relates to polymer blends and more particularly to cyclic olefin containing polymers or bridged polycyclic hydrocarbon containing polymers blended with ethylene and  $\alpha$ -olefin copolymers that are obtained utilizing a metallocene catalyst system.

### BACKGROUND ART

In the medical field, where beneficial agents are collected, processed and stored in containers, transported and ultimately delivered through drip chambers, tube connectors and tubes by infusion to patients, there has been a recent trend toward developing materials useful for fabricating such containers, tubings and devices without the disadvantages of currently used materials such as polyvinyl chloride. These new materials must have a unique combination of properties to be used in fluid administration sets. Among these are the materials in most instances must be optically clear, environmentally compatible, have sufficient yield strength and flexibility for flexible products and sufficient rigidity for rigid products, have a low quantity of low molecular weight additives, be capable of being solvent bonded to soft polyolefin medical products and be compatible with medical solutions.

It is desirable for medical products in an infusion delivery set to be optically transparent to allow for visual inspection of fluids therein.

It is also desirable that the medical materials be environmentally compatible as a great deal of medical products are disposed of in landfills and through incineration. Further benefits are realized by using a material which is thermoplastically recyclable.

For medical products that are disposed of by incineration, it is necessary to use a material that does not generate or minimizes the formation of by-products such as inorganic acids which may be environmentally harmful, irritating, and corrosive. For example, PVC may generate objectionable amounts of hydrogen chloride (or hydrochloric acid when contacted with water) upon incineration, causing corrosion of the incinerator.

To be compatible with medical solutions, it is desirable that the components of the infusion delivery set be free from or have a minimal content of low molecular weight additives such as plasticizers, stabilizers and the like. In some applications, these components can be extracted into the therapeutic solutions that come into contact with the material. The additives may react with the therapeutic agents or otherwise render the solution ineffective. This is especially troublesome in bio-tech drug formulations where the concentration of the drug is measured in parts per million (ppm), rather than in weight or volume percentages. Even minuscule losses of the bio-tech drug can render the formulation unusable. Because bio-tech formulations can cost several thousand dollars per dose, it is imperative that the dosage not be changed.

Polyvinyl chloride ("PVC") has been widely used to fabricate medical tubings and containers as it meets most of these requirements. However, because PVC by itself is a rigid polymer, low molecular weight components known as plasticizers must be added to render PVC flexible. These plasticizers may leach out of the medical product and into the fluid passing through the products to contaminate the

fluid or to render the fluid unusable. For this reason, and because of the difficulties encountered in incinerating PVC, there is a need to replace PVC in at least the fluid contacting portions of the infusion pathway and more preferably in its entirety.

Polyolefins have been developed which meet many of the requirements of medical containers and tubing, without the disadvantages associated with PVC. Polyolefins typically are compatible with medical applications because they have minimal extractability to the fluids and contents which they contact. Most polyolefins are environmentally sound as they do not generate harmful degradants upon incineration, and in most cases are capable of being thermoplastically recycled. Many polyolefins are cost effective materials that may provide an economic alternative to PVC. However, there are many hurdles to overcome to replace all the favorable attributes of PVC with a polyolefin.

For example, because of the inert nature of polyolefins, due in part to the non-polar nature of the polymer, difficulties have been encountered in bonding the polyolefin materials to rigid housings positioned along the infusion pathway of an infusion set. Typically, medical containers such as I.V. bags are connected to a patient through a series of connected tubing that have in fluid communication drip chambers, Y-type injection sites, venous catheters and the like between the bag and the patient. Many of these components include rigid housings manufactured from polycarbonates, acrylics, ABS, copolyesters and the like. The housings have sleeves in which the tubing is inserted in a telescoping fashion to attach the tube to the housing. Therefore, it is necessary for the medical tubing to be connected to the rigid housing to form a fluid tight seal with the housings.

PVC tubing is typically secured within such housings using solvent bonding techniques. Solvent bonding requires exposing the end of the tubing to be inserted into the housing to a solvent such as cyclohexanone or methyl ethyl ketone. The solvent effectively softens or dissolves the PVC so when the tubing is inserted into the housing, a bond is formed. Solvent bonding techniques, however, are ineffective on certain polyolefins including polyethylene and polypropylene. Problems have also been encountered in using adhesive bonding techniques.

European Patent Application No. 0 556 034 discloses a medical instrument of a material containing a resin of a cyclic olefin compound or a bridged polycyclic hydrocarbon compound. The EP '034 Application discloses making devices such as syringes, injection needles, drip chambers, blood bags and tubing from these resins. While the EP '034 Patent application discloses a non-PVC material for fabricating medical products it does not disclose a method for bonding a rigid housing of a cyclic olefin to a flexible tubing of a cyclic olefin or other polyolefins.

Cycloolefin blends are also well known for providing rigid, injection molded parts. For example, U.S. Pat. No. 5,359,001 discloses a multiple component polymer blend having a first component of a cycloolefin, a second component of a polyolefin and a third component of a cycloolefin block copolymer to compatibilize the cycloolefin and polyolefin. The '001 Patent discloses such blends for impact modifying the highly rigid and brittle cycloolefins. The '001 Patent does not disclose a method for solvent bonding these blends.

U.S. Pat. No. 5,863,986 discloses polymer alloy blends of a cycloolefin copolymers with one or more core-shell particles and one or more block copolymers. Again, these polymer blends are tough on impact and have high flexural

strength and elongation at break. The '986 patent does not disclose a method for solvent bonding the polymer alloy blends.

### DISCLOSURE OF INVENTION

The present invention provides multiple component polymer blends for fabricating medical devices. The blends of the present invention contain as a component homopolymers or copolymers of cyclic olefins or bridged polycyclic hydrocarbons. For example, the present invention provides a polymer composition comprising: a first component obtained by copolymerizing a norbornene monomer and an ethylene monomer, the first component being in an amount from about 1–99% by weight of the composition; and a second component of an ethylene and  $\alpha$ -olefin copolymer, the  $\alpha$ -olefin having 6 carbons, the second component being in an amount from about 99% to about 1% by weight of the composition. It has been found by the present inventors that  $\alpha$ -olefin having 6 carbons when blended with norbornene result in blends having greater clarity when compared with blends of norbornene with  $\alpha$ -olefins having 4 or 8 carbons. In a preferred form of the invention the ethylene and  $\alpha$ -olefin copolymer is obtained using a metallocene catalyst.

The present invention also provides three component polymer blends where a second homopolymer or copolymer of a cyclic olefin or a bridged polycyclic hydrocarbon is added to the above-described two-component blend. In a preferred form of the invention, the norbornene has a glass transition temperature of lower than 120° C. and the second homopolymer or copolymer of a cyclic olefin or a bridged polycyclic hydrocarbon has a glass transition temperature of higher than 120° C.

### BRIEF DESCRIPTION OF DRAWINGS

FIG. 1 shows a diagrammatic view of an infusion delivery set; and

FIG. 2 shows a diagrammatic view of a syringe barrel having end closures solvent bonded thereto.

### BEST MODE FOR CARRYING OUT THE INVENTION

While the invention is susceptible of embodiment in many different forms, there is shown in the drawings and will herein be described in detail preferred embodiments of the invention with the understanding that the present disclosure is to be considered as an exemplification of the principles of the invention and is not intended to limit the broad aspect of the invention to the embodiments illustrated.

FIG. 1 shows an infusion delivery set **10** having an I.V. container **12** and port tube **14** connected to a tubing **16** which provides at its distal end a venous catheter **18** for establishing fluid-flow access to a vascular system of a patient. Positioned at intermediate portions of the infusion pathway is a drip chamber **20** and a Y-type injection site **22**. It should be understood that other rigid medical housings include filter housings, tubing unions and others well known in the art, and that these components could be used in any combination in a delivery set **10**. FIG. 2 shows a syringe barrel **24** having end closures **26** solvent bonded on opposite ends of the syringe barrel. Of course the end closure **26** can be on one or both ends of the syringe barrel **24**.

As will be described below, the present invention provides polymers and copolymers containing monomers of cyclic olefins (which sometimes shall be referred to as cyclic olefin containing polymers) and blends thereof as well as

homopolymers and copolymers containing monomers of bridged polycyclic hydrocarbons (which sometimes shall be referred to as bridged polycyclic hydrocarbon containing polymers) and blends thereof to fabricate both the flexible, rigid and semi-rigid components of the delivery set **10** and further provides solvent bonding and cement bonding techniques for attaching together olefin components to fabricate medical device assemblies and subassemblies contained in an infusion set or other medical devices well known in the medical arts.

The term polyolefin used herein is meant to include homopolymers and copolymers of ethylene, propylene, butene, pentene, hexene, heptene, octene, nonene, and decene. Suitable copolymers of ethylene include: (a) ethylene copolymerized with monomers selected from the group of  $\alpha$ -olefins having 3–10 carbons, lower alkyl and lower alkene substituted carboxylic acids and ester and anhydride derivatives thereof, (b) ethylene propylene rubbers, (c) EPDM, and (d) ionomers. Preferably, the carboxylic acids have from 3–10 carbons. Such carboxylic acids therefore include acetic acid, acrylic acid and butyric acid. The term “lower alkene” and “lower alkyl” is meant to include a carbon chain having from 3–18 carbons more preferably 3–10 and most preferably 3–8 carbons. Thus, a subset of this group of comonomers includes, as a representative but non-limiting example, vinyl acetates, vinyl acrylates, methyl acrylates, methyl methacrylates, acrylic acids, methacrylic acids, ethyl acrylates, and ethyl acrylic acids.

#### I. Cyclic Olefins and Bridged Polycyclic Hydrocarbons

Suitable homopolymer and copolymers of cyclic olefins and bridged polycyclic hydrocarbons and blends thereof can be found in U.S. Pat. Nos. 5,218,049, 5,854,349, 5,863,986, 5,795,945, 5,792,824; EP 0 291,208, EP 0 283,164, EP 0 497,567 which are incorporated in their entirety herein by reference and made a part hereof. In a preferred form of the invention these homopolymers, copolymers and polymer blends will have a glass transition temperature of greater than 50° C., more preferably from about 70° C. to about 180° C., a density greater than 0.910 g/cc and more preferably from 0.910 g/cc to about 1.3 g/cc and most preferably from 0.980 g/cc to about 1.3 g/cc and have from at least about 20 mole % of a cyclic aliphatic or a bridged polycyclic in the backbone of the polymer more preferably from about 30–65 mole % and most preferably from about 30–60 mole %.

In a preferred form of the invention, suitable cyclic olefin monomers are monocyclic compounds having from 5 to about 10 carbons in the ring. The cyclic olefins can be selected from the group consisting of substituted and unsubstituted cyclopentene, cyclopentadiene, cyclohexene, cyclohexadiene, cycloheptene, cycloheptadiene, cyclooctene, cyclooctadiene. Suitable substituents include lower alkyl, acrylate derivatives and the like.

In a preferred form of the invention, suitable bridged polycyclic hydrocarbon monomers have two or more rings and more preferably contain at least 7 carbons. The rings can be substituted or unsubstituted. Suitable substituents include lower alkyl, aryl, aralkyl, vinyl, allyloxy, (meth) acryloxy and the like. The bridged polycyclic hydrocarbons are selected from the group consisting of those disclosed in the above incorporated patents and patent applications. Suitable bridged polycyclic hydrocarbon containing polymers are sold by Ticona under the tradename TOPAS, by Nippon Zeon under the tradename ZEONEX and ZEONOR, by Daikyo Gomu Seiko under the tradename CZ resin, and by Mitsui Petrochemical Company under the tradename APEL.

Suitable comonomers include  $\alpha$ -olefins having from 3–10 carbons, aromatic hydrocarbons, other cyclic olefins and bridged polycyclic hydrocarbons.

It may also be desirable to have pendant groups associated with the above-mentioned homopolymers and copolymers. The pendant groups are for compatibilizing the cyclic olefin containing polymers and the bridged polycyclic hydrocarbon containing polymers with more polar polymers including amine, amide, imide, ester, carboxylic acid and other polar functional groups. Suitable pendant groups include aromatic hydrocarbons, carbon dioxide, monoethylenically unsaturated hydrocarbons, acrylonitriles, vinyl ethers, vinyl esters, vinylamides, vinyl ketones, vinyl halides, epoxides, cyclic esters and cyclic ethers. The monethylenically unsaturated hydrocarbons include alkyl acrylates, and aryl acrylates. The cyclic ester includes maleic anhydride.

## II. Blends Containing Cyclic Olefin Containing Polymers and/or Bridged Polycyclic Hydrocarbon Containing Polymers

Suitable two-component blends of the present invention include as a first component the homopolymers and copolymers of the cyclic olefin containing polymers and the bridged polycyclic hydrocarbon containing polymers (collectively hereinafter sometimes referred to as "COCs") described above in Section I. The COCs should be present in an amount from about 1–99% by weight of the blend, more preferably from about 30–99%, and most preferably from about 35–99 weight percent or any combination or subcombination or ranges therein. In a preferred form of the invention the first components has a glass transition temperature of from about 70° C. to about 130° C. and more preferably from about 70–110° C.

The blends further include a second component in an amount by weight of the blend of from about 99–1%, more preferably from about 70–1% and most preferably from about 65–1%. The second component is selected from the group consisting of homopolymers and copolymers of ethylene, propylene, butene, hexene, octene, nonene, decene and styrene. The second component preferably has a density of from about 0.870–0.960 g/cc and more preferably from about 0.910–0.960 g/cc and more preferably from about 0.930–0.960 g/cc. In a preferred form of the invention the second component is and ethylene and  $\alpha$ -olefin copolymer where the  $\alpha$ -olefin has from 3–10 carbons, more preferably from 4–8 carbons and most preferably 6 carbons. Most preferably the ethylene and  $\alpha$ -olefin copolymers are obtained using a metallocene catalyst.

Suitable three-component blends include as a third component a COC selected from those COCs described in Part I above and different from the first component. In a preferred form of the invention the second COC will have a glass transition temperature of higher than about 120° C. when the first COC has a glass transition lower than about 120° C. In a preferred form of the invention, the third component is present in an amount by weight of from about 10–90% by weight of the blend and the first and second components should be present in a ratio of from about 2:1 to about 1:2 respectively of the first component to the second component.

In a preferred form of the invention, random and block copolymers of norbornene and ethylene are selected as the first component of the blend. These norbornene copolymers are described in detail in U.S. Pat. Nos. 5,783,273, 5,744,664, 5,854,349, and 5,863,986. The norbornene ethylene copolymer preferably has from at least about 20 mole percent norbornene monomer and more preferably from about 20–75 mole percent and most preferably from about 30–60 mole percent norbornene monomer or any combination or subcombination of ranges therein. The norbornene ethylene copolymer should have a glass transition temperature of from about 70–180° C., more preferably from 70–130° C. and even more preferably from about 70–100° C.

The second component is preferably an ethylene copolymerized with an  $\alpha$ -olefin having 6 carbons. It has been found by the present inventors that using this ethylene and a 6 carbon  $\alpha$ -olefin as the second component yields blends with higher clarity when compared to blends having ethylene copolymerized with  $\alpha$ -olefins having 4 or 8 carbons. Preferably, the ethylene and  $\alpha$ -olefin copolymers are obtained using metallocene catalysts. Suitable catalyst systems, among others, are those disclosed in U.S. Pat. Nos. 5,783,638 and 5,272,236. Suitable ethylene and  $\alpha$ -olefin copolymers include those sold by Dow Chemical Company under the AFFINITY and ENGAGE tradenames, those sold by Exxon under the EXACT tradename and those sold by Phillips Chemical Company under the tradename MAR-LEX.

As set forth above, the first component of the norbornene/ethylene copolymer can be present from about 1–99% by weight of the blend, more preferably from about 30–99% by weight, and most preferably 35–99% by weight.

In a preferred three-component blend a second norbornene and ethylene copolymer is added to the two component norbornene-ethylene/ethylene 6 carbon  $\alpha$ -olefin blend. The second norbornene ethylene copolymer should have a norbornene monomer content of 30 mole percent or greater and more preferably from about 35–75 mole percent and a glass transition temperature of higher than 120° C. when the first component has a glass transition temperature of lower than 120° C.

## III. Medical Products

Medical devices such as those shown in FIG. 1 may be fabricated from the COCs set forth above. The present invention provides for fabricating, rigid, semi-rigid and flexible devices from the COCs. What is meant by the use of the term "rigid" herein is parts having a modulus of elasticity of at least 150,000 psi when measured in accordance with ASTM D790. What is meant by the term "semi-rigid" is parts having a modulus of elasticity of greater than 20,000 psi but less than 150,000 psi when measured in accordance with ASTM D790. What is meant by the term "flexible" is articles having a modulus of elasticity of less than about 20,000 psi when measured in accordance with ASTM D790.

Rigid parts such as Y-sites, filter housings, injection sites, spikes, syringe barrels, closures and others may be fabricated from the COCs by injection molding, blow molding, thermoforming processes or other plastic fabricating techniques. Semi-rigid parts such as drip chambers and closures may be fabricated from injection molding, blow molding, thermoforming and extrusion processes. Flexible parts such as medical tubing, closures and medical containers may be obtained using extrusion, coextrusion, lamination, blow molding and injection molding processes.

For flexible and semi-rigid components such as tubing, containers and drip chamber 20, suitable polymers also include other polyolefins such as ethylene vinyl acetate copolymers having a vinyl acetate content of from about 5% to about 32%, ethylene methacrylate copolymers, ethylene and  $\alpha$ -olefin copolymers having a density of less than 0.910 g/cc, flexible polypropylenes such as Huntsman's REFLEX and Montell's ADFLEX and stereo block homopolymers of polypropylene disclosed in U.S. Pat. No. 5,594,080. Suitable polymers also include polymer blends and films such as those disclosed in U.S. Pat. No. 5,849,843 and U.S. patent application Ser. No. 08/153,602.

## IV. Method of Solvent Bonding COCs

The present invention provides a method for assembling components of an infusion set into medical assemblies using solvent bonding techniques. Solvent bonding techniques can

be used to join together any combination of rigid, semi-rigid and flexible parts including joining two rigid components, a rigid component to a semi-rigid component, a rigid component to a flexible component, a semi-rigid component to a flexible component, a semi-rigid component to another semi-rigid component, and certain flexible components to one another.

The method of solvent bonding includes the steps of: (1) providing a first article of a polymer composition described above in Sections I and II such as those having a first component of cyclic olefin containing polymer or a bridged polycyclic hydrocarbon containing polymer, the first component being present in an amount from about 30% to about 100% by weight of the composition; (2) providing a second article of a material selected from the group comprising low crystallinity polymers; (3) applying a solvent to one of the first article or the second article to define an interface area; and (4) bonding the first article to the second article along the interface area. Suitable low crystallinity polymers to fabricate the second article include COCs, COC blends having minimally 30% COC by weight, polymethyl pentene, polyolefins having a modulus of elasticity of less than 10,000 psi when measured in accordance with ASTM D790, and styrene containing polymers without modulus limitations.

Suitable solvents are those having a solubility parameter of less than about 20 (MPa)<sup>1/2</sup>, more preferably less than about 19 (MPa)<sup>1/2</sup> and most preferably less than about 18 (MPa)<sup>1/2</sup> and include, but are not limited to, aliphatic hydrocarbons, aromatic hydrocarbons, mixtures of aliphatic hydrocarbons, mixtures of aromatic hydrocarbons and mixtures of aromatic and aliphatic hydrocarbons. Suitable aliphatic hydrocarbons include substituted and unsubstituted hexane, heptane, cyclohexane, cycloheptane, decalin, and the like. Suitable aromatic hydrocarbons include substituted and unsubstituted aromatic hydrocarbon solvents such as xylene, tetralin, toluene, and cumene. Suitable hydrocarbon substituents include aliphatic substituents having from 1-12 carbons and include propyl, ethyl, butyl, hexyl, tertiary butyl, isobutyl and combinations of the same. What is meant by the terms "aliphatic hydrocarbon" and "aromatic hydrocarbon" is a compound containing only carbon and hydrogen atoms. Suitable solvents will also have a molecular weight less than about 200 g/mole, more preferably less than about 180 g/mole and most preferably less than about 140 g/mole.

The first article can be rigid, semi-rigid and flexible medical product selected from the group consisting of Y-sites, filter housings, drip chambers, heparin locks, injection sites, catheters, spikes, syringe barrels, closures, tubings, oxygenators, pump cassettes, valves, burretes, and any medical article or component. The second article can be rigid, semi-rigid and flexible polymeric material selected from the group comprising polyolefins, styrene containing polymers, cyclic olefin containing polymers and bridged polycyclic hydrocarbon containing polymers. The second article can be of the same device set forth for the first article.

In a preferred form of the invention, the method comprises the steps of: (1) providing a first article of a polymer composition comprising: (a) a first component obtained by polymerizing a norbornene monomer and an ethylene monomer, the norbornene monomer being present in an amount of at least about 20 mole percent of the copolymer, the first component being present in an amount from about 30% to about 100% by weight of the composition; and (b) a second component of a first ethylene and  $\alpha$ -olefin copolymer, the second component being in an amount from

about 70% to about 0% by weight of the composition; (2) providing a second article of low crystallinity polymers; (3) applying a solvent to one of the first article or the second article to define an interface area; and (4) bonding the first article to the second article along the interface area.

#### V. COC Cement

For those flexible polymers that do not bond well to other flexible polymers using the solvent bonding techniques described above in Section IV, the present invention provides a cyclic olefin containing polymer based cement composition or bridged polycyclic hydrocarbon containing polymer based cement composition. The first component of the cement composition is selected from those set forth in Section I above and include a homopolymer or copolymer of a cyclic olefin or a bridged polycyclic hydrocarbon in an amount from 1-20% by weight of the composition, more preferably from 1-15% and most preferably from 3-10%, and a second component of a solvent having a solubility parameter of less than about 20 (MPa)<sup>1/2</sup> more preferably less than about 19 (MPa)<sup>1/2</sup> and most preferably less than about 18 (MPa)<sup>1/2</sup> and more preferably selected from the group of aliphatic hydrocarbons and aromatic hydrocarbons set forth above in Section IV. Suitable solvents will also have a molecular weight less than about 200 g/mole, more preferably less than about 180 g/mole and most preferably less than about 140 g/mole.

These cement compositions can also be used for bonding flexible articles to rigid articles, flexible articles to semi-rigid articles, semi-rigid articles to one another or for bonding semi-rigid articles to rigid articles or for bonding rigid articles to one another. Accordingly, the cement compositions can be used to prepare medical device assemblies such as joining flexible tubings to one another, joining flexible tubings to tubing unions and flexible tubings to drip chambers, flexible tubings to Y-sites and other rigid housings or any of the components of the medical infusions set or other medical device assemblies.

It may also be desirable to include in the cement composition polymer resins from the articles being joined. These optional components can be added in an amount by weight of the composition from 0-10%, more preferably from 0.2-5% and most preferably from 0.2-3%. The third component can be selected from the group comprising polyethylene copolymers having a density less than 0.880 g/cc, polymethyl pentene, polypropylene having a modulus of less than 10,000 psi and more preferably less than 4,000 psi, and certain styrene containing copolymers and interpolymers. Typically these flexible type polypropylenes are atactic. Certain polypropylene copolymers with ethylene are also suitable. Suitable styrene containing polymers include Dow's interpolymers of styrene sold under the tradename INDEX. Other suitable styrene containing polymers include SBS, SIS and hydrogenated derivatives thereof such as SEBS and SEPS.

The method of using a polymeric cement to assemble medical devices comprises the steps of: (1) providing a first article of a low crystallinity polymer set forth above; (2) providing a second article of a low crystallinity polymer set forth above; (3) providing a cement composition having a first component of a cyclic olefin containing polymer or a bridged polycyclic hydrocarbon containing polymer and a second component of an effective amount of a solvent having a solubility parameter of less than about 20 (MPa)<sup>1/2</sup> and more preferably selected from the group of aliphatic hydrocarbons and aromatic hydrocarbons having a molecular weight less than about 200 g/mole; (4) applying the cement composition to one of the first and second articles to

define a bonding area; and (5) attaching the first article to the second article along the bonding area to fixedly attach the first article to the second article.

Suitable polyolefins for the first and second articles can be selected from the group comprising homopolymers and copolymers of ethylene, propylene, butene, pentene, hexene, heptene, octene, nonene, and decene. Suitable copolymers of ethylene include: (a) ethylene copolymerized with monomers selected from the group of  $\alpha$ -olefins having 3–10 carbons, lower alkyl and lower alkene substituted carboxylic acids and ester and anhydride derivatives thereof, (b) ethylene-propylene rubbers, (c) EPDM, and (d) ionomers. Preferably, the carboxylic acids have from 3–10 carbons. Such carboxylic acids therefore include acetic acid, acrylic acid and butyric acid. The term “lower alkene” and “lower alkyl” is meant to include a carbon chain having from 3–18 carbons more preferably 3–10 and most preferably 3–8 carbons. Thus, a subset of this group of comonomers includes, as a representative but non-limiting example, vinyl acetates, vinyl acrylates, methacrylates, methyl methacrylates, acrylic acids, methyl acrylic acids, ethyl acrylates, and ethyl acrylic acids.

The first component of the cement composition can also be a copolymer of the cyclic olefins or the bridged polycyclic hydrocarbons set forth above in Section I. Suitable comonomers of the COCs can be selected from the group comprising  $\alpha$ -olefins having from 2–10 carbons, aromatic hydrocarbons, cyclic hydrocarbons, and bridged polycyclic hydrocarbons. In a preferred form of the invention the first component is a copolymer of a norbornene monomer and an ethylene monomer and more preferably the norbornene monomer is present in at least about 20 mole percent of the copolymer and even more preferably the norbornene is present from about 30 to about 60 mole percent.

The cement composition can also have an additional optional component selected from the group of polyethylene copolymers having a density less than about 0.880 g/cc, polymethyl pentene, polypropylene having a modulus of less than about 10,000 psi and more preferably less than about 4,000 psi, and certain styrene containing copolymers and interpolymers. Typically these flexible type polypropylenes are atactic. Certain polypropylene copolymers with ethylene are also suitable. Suitable styrene and ethylene containing polymers include Dow's interpolymer of styrene sold under the tradename INDEX. Other suitable styrene containing polymers include SBS, SIS and hydrogenated derivatives thereof such as SEBS and SEPS.

In a preferred form of the invention, the method for using a polymeric cement to assemble medical devices comprises the steps of: (1) providing a first article of a low crystallinity polymer set forth above; (2) providing a second article of a low crystallinity polymer set forth above; (3) providing a cement composition comprising: (a) a first component in an amount by weight of from 1–20% of the cement composition and obtained by copolymerizing a norbornene monomer and an ethylene monomer, the norbornene monomer being present in an amount of at least about 20 mole percent of the copolymer; (b) a second component of a solvent in an amount by weight from about 99% to about 80% of the cement composition; and (c) an optional third component in an amount by weight from about 0–10% by weight of the cement composition and selected from the group of optional components set forth above; (4) applying the cement composition to one of the first and second articles to define a bonding area; and (5) attaching the first article to the second article along the bonding area to fixedly attach the first article to the second article.

The present invention also provides a medical device assembly. The assembly has a first article of a first polymeric material selected from the group comprising polyolefins, styrene containing polymers, cyclic olefin containing polymers and bridged polycyclic hydrocarbon containing polymers. The assembly also has a second article of a polymeric material selected from the group comprising polyolefins, styrene containing polymers, cyclic olefin containing polymers and bridged polycyclic hydrocarbon containing polymers. The first article is attached to the second article with a cement composition. The cement composition has a first component of a cyclic olefin containing polymer or a bridged polycyclic hydrocarbon containing polymer and an effective amount of a solvent having a solubility parameter of less than about 20 (MPa)<sup>1/2</sup> and more preferably selected from the group of aliphatic hydrocarbons and aromatic hydrocarbons having a molecular weight less than about 200 g/mole. The following are non-limiting examples of the present invention.

## EXAMPLES

### Example I.

Test Methods for Resin Properties:

Tensile Modulus: ASTM D638.

Flexural Modulus: ASTM D790.

Glass Transition Temperature: DSC.

Light Transmittance: ASTM D1003.

### Example II.

Resin Properties:

(1) COC Resins:

Topas resins are produced by Ticona, a member of the Hoechst Group.

CZ Resin is marketed by the Daikyo Gomu Seiko and The West Company.

Zeonex resin is produced by Nippon Zeon Co.,Ltd.

Resin	Glass Transition Tg. (° C.)	Tensile Modulus (kpsi)	Light Transmittance (%)
Topas 8007	85	377	92
Topas 6013	130	464	92
Topas 6015	160	464	92
Topas 6017	180	464	92
CZ Resin	140	341	91
Zeonex 280	140	341	91

(2) Non-COC Resins:

Material	Tensile/Flexural Modulus (kpsi)	Density (g/cc)	Comonomer
<u>Polyethylene:</u>			
Dow Chemicals Affinity VP8770	5	0.885	Octene
Dow Chemicals Affinity PL1880	12	0.903	Octene
Du Pont Dow Engage 8003	5	0.885	Octene
Du Pont Dow Engage 8411	3	0.880	Octene
Dow Chemicals Dowlex 2045	38	0.920	Octene
Mitsui Tafmer A4085	5	0.885	Butene
Exxon Exact 3024	14	0.905	Butene

-continued

Material	Tensile/ Flexural Modulus (kpsi)	Density (g/cc)	Comonomer
Exxon Exact 3128	12	0.900	Butene
Exxon Exact 4033	3	0.880	Butene
Exxon Exact 3030	14	0.905	Hexene
Exxon Exact 3131	11	0.900	Hexene
Phillips Marlex mPACT D143	23	0.916	Hexene
Phillips Marlex mPACT D350	64	0.933	Hexene
<u>Polypropylene:</u>			
Huntsman Rexflex W304	2	0.88	
Huntsman Rexflex W210 EVA	4	0.89	
Du Pont Elvax CM576	2.5	0.95	
<u>Polybutene</u>			
Montell PB0200	35	0.915	
Montell PB8340	32	0.908	
<u>Styrenic copolymer</u>			
Phillips K-Resin KR03	210	1.01	
Shell Kraton G 1657	0.4	0.90	

(3) Solvents Used in the Examples:

All solvents were purchased from the Sigma-Aldrich Co.

The solubility parameters reported below are the Hansen Solubility Parameters at 25 degree C., as listed in the Polymer Handbook, 3<sup>rd</sup> Ed., Chapter VII, Pages 540-544 unless otherwise specified.

Solvent	Solubility Parameter (MPa) <sup>1/2</sup>	Molecular Weight (g/mol)	Type of compound
Cyclohexane	16.8	84	Aliphatic hydrocarbon
Methyl cyclohexane	16.0	98	Aliphatic hydrocarbon
Ethyl cyclohexane	16.3*	112	Aliphatic hydrocarbon
Propyl cyclohexane	16.2*	126	Aliphatic hydrocarbon
n-Butyl cyclohexane	16.2*	140	Aliphatic hydrocarbon
t-Butyl cyclohexane	—	140	Aliphatic hydrocarbon
Decalin	18.0-18.8	138	Aliphatic hydrocarbon
Heptane	15.3	100	Aliphatic hydrocarbon
Xylene	18.0	106	Aromatic hydrocarbon
Tetralin	20.0	132	Aromatic hydrocarbon
Cumene	17.6*	120	Aromatic hydrocarbon
Toluene	18.2	92	Aromatic hydrocarbon
Cyclohexanone	19.6	98	Ketone
Methyl ethyl ketone	19.0	72	Ketone
Methylene chloride	20.3	85	Halohydrocarbon
Tetrahydrofuran	19.4	72	Ether
Dimethyl formamide	24.8	73	Nitrogen containing compound
Dimethyl sulfoxide	26.6	78	Sulfur containing Compound

\*Data from CRC Handbook of Solubility Parameters and Other Cohesion Parameters, 2<sup>nd</sup> Ed.

Example III.

Test Articles and Solvent Bonding Test Results:

All the COC blends set forth in the table below were prepared using a Brabender mixer, mixed at 250° C. at 50 rpm for about 4 minutes, and then compression molded into 0.010" to 0.025" thick sheets at 450° F.

COC Blend Composition	Blend Ratio (wt %)	Material Rigidity	Strength of Solvent Bonding <sup>(1)</sup>		
			to ULDPE <sup>(2)</sup> (flexible)	to EVA <sup>(3)</sup> (flexible)	to COC <sup>(3)</sup> (rigid)
5					
10	0/100	flexible	none	none	good
Tafmer A4085	30/70	semi-rigid	weak	weak	good
	50/50	rigid	good	good	strong
	70/30	rigid	strong	strong	strong
Topas 8007/ Affinity VP8770	0/100	flexible	none	none	good
	50/50	rigid	good	good	strong
15	0/100	flexible	none	none	weak
Topas 8007/ Affinity PL1880	50/50	rigid	good	good	strong
	0/100	flexible	none	none	good
	50/50	rigid	good	good	strong
Topas 8007/ Engage 8411	0/100	flexible	none	none	weak
	50/50	rigid	good	good	strong
	70/30	rigid	strong	strong	strong
Topas 8007/ Exact 3024	0/100	flexible	none	none	weak
	50/50	rigid	good	good	strong
	70/30	rigid	strong	strong	strong
20	0/100	flexible	none	none	weak
	50/50	rigid	good	good	strong
	70/30	rigid	strong	strong	strong
Topas 8007/ Exact 3128	0/100	flexible	none	none	weak
	50/50	rigid	good	good	strong
	70/30	rigid	strong	strong	strong
Topas 8007/ Exact 4033	0/100	flexible	none	none	good
	50/50	rigid	good	good	strong
	70/30	rigid	strong	strong	strong
25	40/60	semi-rigid	weak	weak	good
	50/50	rigid	good	good	strong
	60/40	rigid	strong	strong	strong
Topas 8007/ Engage 8003	70/30	rigid	strong	strong	strong
	80/20	rigid	strong	strong	strong
	90/10	rigid	strong	strong	strong
30	0/100	semi-rigid	none	none	none
	50/50	rigid	good	good	strong
	30/70	rigid	weak	weak	good
Topas 6015/ Tafmer A4085	50/50	rigid	good	good	strong
	70/30	rigid	good	good	strong
	0/100	flexible	none	none	good
35	30/70	semi-rigid	weak	weak	good
	50/50	rigid	good	good	strong
	70/30	rigid	strong	strong	strong
Topas 8007/ Rexflex W304	0/100	semi-rigid	none	none	none
	50/50	rigid	good	good	strong
	70/30	rigid	strong	strong	strong
40	0/100	semi-rigid	none	none	none
	50/50	rigid	good	good	strong
	30/70	semi-rigid	none	none	none
Topas 8007/ PB0200	50/50	rigid	good	good	strong
	50/50	rigid	good	good	strong
	50/50	rigid	good	good	strong
45	50/50	rigid	good	good	strong
	70/30	rigid	good	good	strong
	0/100	flexible	none	none	good
Topas 8007/ Kraton G1657	30/70	semi-rigid	weak	weak	good
	50/50	rigid	good	good	strong
	70/30	rigid	good	good	strong
50	0/100	rigid	none	none	weak
	50/50	rigid	good	good	strong
	50/50	rigid	good	good	strong
Topas 8007/ K-Resin KR01	60/20/20	rigid	good	good	strong
	25/25/50	rigid	good	good	strong
	30/20/50	rigid	good	good	strong
55	25/25/50	rigid	good	good	strong
	30/20/50	rigid	good	good	strong
	25/25/50	rigid	good	good	strong

<sup>(1)</sup>The solvent used is cyclohexane.

Bond strength was assessed by hand pull test, at one day after the solvent bonding.

Ratings:

None = Readily separable.

Weak = Some bond strength but easy to separate.

Good = Hard to separate, no material transfer is visible on the peeled surface but is suitable for providing a sterile, sturdy connection.

65



-continued

COC Blend Composition	Blend Ratio (wt %)	Material Rigidity	Strength of Solvent Bonding <sup>(1)</sup>		
			to ULDPE <sup>(2)</sup> (flexible)	to EVA <sup>(3)</sup> (flexible)	to COC <sup>(3)</sup> (rigid)

Strong = Very hard to separate, material transferring from one surface to another at the peeling bonding interface is visible.

<sup>(2)</sup>The ULDPE specimen was made from Dow Chemicals Engage 8003 resin and was extruded into a tube.

<sup>(3)</sup>The EVA specimen was made from DuPont Elvax CM576 resin which had 28% VA content, and was extruded into a tube.

<sup>(4)</sup>The COC specimen was made from Topas 8007 resin and was injection molded into y-site with the bonding site in a tube geometry.

IV. Examples of Using Different Solvents to Bond COC Containing Devices:

Combination	Material-1 to Material-2	Solvent	Bond Strength
Rigid to Flexible	Topas 8007 <sup>(a)</sup> to Engage 8003 <sup>(b)</sup>	Cyclohexane	good
		Ethyl cyclo hexane	good
		Propyl cyclo hexane	good
		n-Butyl cyclo hexane	good
		t-Butyl cyclo hexane	good
		Xylene	good
		Tetralin	good
		Decalin	good
		Heptane	good
		Cumene	good
		Toluene	weak
		Cyclohexanone	none
		Methyl ethyl ketone	none
		Methylene chloride	none
		Tetrahydrofuran	none
		Dimethyl formamide	none
		Dimethyl sulfoxide	none
Rigid to Flexible	Topas 8007 <sup>(a)</sup> to Elvax CM576 <sup>(b)</sup>	Cyclohexane	good
		Ethyl cyclo hexane	good
		Propyl cyclo hexane	good
		n-Butyl cyclo hexane	good
		t-Butyl cyclo hexane	good
		Xylene	good
		Tetralin	good
		Decalin	good
		Heptane	good
		Cumene	good
		Toluene	weak
		Cyclohexanone	none
		Methyl ethyl ketone	none
		Methylene chloride	none
		Tetrahydrofuran	none
		Dimethyl formamide	none
		Dimethyl sulfoxide	none
Rigid to Rigid	Topas 8007 <sup>(c)</sup> to Topas 8007 <sup>(c)</sup>	Cyclohexane	strong
		n-Butyl cyclo hexane	strong
		Xylene	strong
		Tetralin	strong
		Heptane	strong

Note:

<sup>(a)</sup>Injection molded into y-site.

<sup>(b)</sup>Extruded tubing.

<sup>(c)</sup>Compression molded sheet.

Bond strength was assessed by hand pull test, at one day after the solvent bonding.

Ratings:

None = Readily separable.

Weak = Some bond strength but easy to separate.

Good = Hard to separate, no material transfer is visible on the peeled surface but is suitable for providing a sterile, sturdy connection.

Strong = Very hard to separate, material transferring from one surface to another at the peeled bonding interface is visible.

V. Examples of Cements Made by Dissolving the COC Resin in Solvents for Bonding Flexible Polyolefin Components:

The COC cements were prepared by dissolving the COC into a solvent at room temperature. Elevated temperature such as 50° C. can be used to enhance the speed of the preparation of the cement solution.

	Cement formulation	Composition	
5	A	coc resin: Topas 8007	1% wt
		solvent: Cyclohexane	99% wt
10	B	coc resin: Topas 8007	5% wt
		solvent: Cyclohexane	95% wt
15	C	coc resin: Topas 8007	15% wt
		solvent: Cyclohexane	85% wt
20	D	coc resin: Topas 8007	5% wt
		solvent: n-Butyl cyclohexane	95% wt
25	E	coc resin: Topas 8007	5% wt
		solvent: Decalin	95% wt
30	F	coc resin: Topas 8007	5% wt
		solvent: Heptane	95% wt
35	G	coc resin: Topas 5013	5% wt
		solvent: Cyclohexane	95% wt
40	H	coc resin: Topas 5013	20% wt
		solvent: Cyclohexane	80% wt

VI. Examples of Bonding a Flexible Component to a Flexible Component Using COC Cement Compositions of Example IV.

Tubings made of ULDPE (Engage 8003) or EVA (Elvax CM 576) were extruded and cut into segments. Cement was applied between bonding interfaces of the tubing segments identified in the following table. The bonding was done by applying small amount of the cement at the bonding interface. Bond strength was measured by a hand pull test conducted one day after bonding.

	Flexible to flexible bonding	Cement	Bond Strength
45	Engage 8003 to Engage 8003	A	weak
	Engage 8003 to Engage 8003	B	good
	Engage 8003 to Engage 8003	C	good
	Engage 8003 to Engage 8003	D	good
	Engage 8003 to Engage 8003	E	good
	Engage 8003 to Engage 8003	F	good
	Elvax CM 576 to Elvax CM 576	A	weak
	Elvax CM 576 to Elvax CM 576	B	good
	Elvax CM 576 to Elvax CM 576	C	good
	Elvax CM 576 to Elvax CM 576	D	good
50	Elvax CM 576 to Elvax CM 576	E	good
	Elvax CM 576 to Elvax CM 576	F	good
	Elvax CM 576 to Elvax CM 576	G	good
	Elvax CM 576 to Elvax CM 576	H	good

55 Bond strength was assessed by hand pull test, at one day after the bonding.

Ratings:

None = Readily separable.

Weak = Some bond strength but easy to separate.

Good = Hard to separate, no material transfer is visible on the peeled surface but is suitable for providing a sterile, sturdy connection.

Strong = Very hard to separate, material transferring from one surface to another at the peeled bonding interface is visible.

VI. COC Blends

65 Blends of the components set forth in the following table were prepared with a Brabender mixer at 250° C. at 50 rpm for 4 minutes.

15

Films were prepared by compression molding at 450° F. to a thickness about 0.4 mm.

The Haze property is useful for the end user to see through the medical device for the purpose of examining the liquid level, particulates, contamination, or the presence of drugs. Lower haze gives clearer view and higher haze gives a fuzzy view. Low haze is frequently a desirable property for medical devices such as solution containers, drug delivery devices, I.V. and blood sets, dialysis devices, and syringes.

The haze and total light transmittance of the film were measured using a ColorQuest instrument with both sides of the film wetted with isopropyl alcohol to remove the effect of surface roughness.

Example VI A

Blends of COC with Styrenic Copolymers and Polypropylene.

COC Blend Composition	Blend Ratio (wt %)	Light Transmittance (%)	Haze (%)
Topas 8007/Rexflex W304	30/70	70	85
	50/50	75	83
	70/30	75	81
Topas 8007/Kraton G1657	30/70	64	86
	50/50	82	80
	70/30	84	80
Topas 8007/K-Resin KR01	50/50	72	83
Topas 6015/K-Resin KR01	50/50	58	86

Examples VI B-D

Blends of COC with Polyethylene:

Summary:

The polymer blends that have lower haze, i.e. better clarity, are Topas 8007 blended with ethylene copolymers that have hexene comonomer polymerized with metallocene catalyst. The blends with the lowest haze are from the blends with polyethylene with hexene comonomer, polymerized with a metallocene catalyst and with a density of higher than 0.900 and more preferably higher than 0.93 (e.g. Marlex D350).

Example VI B

Blends of Topas 8007 (Tg~80 deg C.) and Polyethylene with Different Comonomers.

COC Blend Composition	Blend Ratio (wt %)	Comonomer in Polyethylene	Light Transmittance (%)	Haze (%)
Topas 8007/Tafmer A4085	30/70	Butene	84	80
	50/50		89	70
	70/30		81	61
Topas 8007/Exact 3024	50/50	Butene	88	83
	50/50	Butene	88	77
	50/50	Butene	81	81
Topas 8007/Exact 3131	50/50	Hexene	93	60
	50/50	Hexene	84	64
	30/70	Hexene	87	53
Topas 8007/MarlexD143	50/50		91	58
	70/30		90	52
	20/80	Hexene	89	54
Topas 8007/MarlexD350	30/70		87	44
	50/50		91	46

16

-continued

COC Blend Composition	Blend Ratio (wt %)	Comonomer in Polyethylene	Light Transmittance (%)	Haze (%)
5	70/30		91	45
	90/10		92	25
10	50/50	Octene	85	72
	50/50	Octene	90	77
	50/50	Octene	91	84

Example VI C

Blends of Topas 6015 (Tg~160 deg C.) and Polyethylene with Different Comonomers.

COC Blend Composition	Blend Ratio	Comonomer in Polyethylene	Light Transmittance (%)	Haze (%)
20	30/70	Butene	65	84
	50/50		78	85
	70/30		47	85
25	30/70	Hexene	76	85
	50/50		83	83
	70/30		77	79
30	30/70	Hexene	54	81
	50/50		80	72
	70/30		79	76
30	30/70	Hexene	86	84
	50/50		82	84
	70/30		62	83

Example VI D

Blends of Topas 6017 (Tg~180 deg C.) Topas 8007 (Tg~80 deg C.) and Polyethylene with Different Comonomers.

Conclusion:

The blend that has reduced haze contains Topas 8007 and a metallocene catalyst polymerized ethylene -hexene copolymer.

COC Blend Composition	Blend Ratio	Comonomer in Polyethylene	Light Transmittance (%)	Haze (%)
45	25/25/50	Octene	65	85
	30/20/50		69	85
50	15/15/70	Hexene	91	69
	25/25/50		82	75
	35/35/30		89	42

It should be understood that any ranges or sets of ranges set forth herein includes any and all ranges, combination or subcombination of ranges therein. While specific embodiments have been illustrated and described, numerous modifications are possible without departing from the spirit of the invention, and the scope of protection is only limited by the scope of the accompanying claims.

what is claimed is:

1. A polymer composition comprising:
  - a first component obtained by copolymerizing a norbornene monomer and an ethylene monomer, the first component being in an amount from about 1–99% by weight of the composition; and
  - a second component of an ethylene and  $\alpha$ -olefin copolymer, the  $\alpha$ -olefin having 6 carbons, the second

component being in an amount from about 99% to about 1% by weight of the composition.

2. The composition of claim 1 wherein the first component has from about 20 to about 75 mole percent of the norbornene monomer.

3. The composition of claim 1 wherein the first component has from about 30 to about 60 mole percent norbornene monomer.

4. The polymer composition of claim 3 wherein the glass transition temperature of the first component is from about 70° C. to about 130° C.

5. The composition of claim 4 wherein the first component is present at least in an amount of about 30% by weight of the composition.

6. The polymer composition of claim 1 wherein the second component is obtained using a metallocene catalyst.

7. The polymer composition of claim 6 wherein the second component has a density from about 0.870 g/cc to about 0.960 g/cc.

8. The composition of claim 1 further comprising a third component of a homopolymer or copolymer obtained using a monomer selected from the group of a cyclic olefin or a bridged polycyclic hydrocarbon.

9. The composition of claim 5 wherein the third component is a second norbornene and ethylene copolymer different from the first component.

10. The composition of claim 9 wherein the third component has a glass transition temperature higher than about 120° C. and the first component has a glass transition temperature lower than about 120° C.

11. The composition of claim 9 wherein the third component is present in an amount from 10% to about 90% by weight of the composition.

12. The composition of claim 11 wherein the first component and second component are present in a ratio of from about 2:1 to about 1:2 by weight.

13. A polymer composition comprising:

a first component obtained by copolymerizing a norbornene monomer and an ethylene monomer, the norbornene monomer being present in an amount of at least about 20 mole percent of the copolymer, the first component being present in an amount from about 30% to about 99% by weight of the composition; and

a second component of an ethylene and  $\alpha$ -olefin copolymer, the  $\alpha$ -olefin having 6 carbons, the second component being in an amount from about 70% to about 1% by weight of the composition.

14. The polymer composition of claim 13 wherein the second component is obtained using a metallocene catalyst.

15. The polymer composition of claim 14 wherein the second component has a density from about 0.870 g/cc to about 0.960 g/cc.

16. The composition of claim 15 further comprising a third component of a homopolymer or copolymer obtained using a monomer selected from the group of cyclic olefin or a bridged polycyclic hydrocarbon.

17. The composition of claim 16 wherein the third component is a second norbornene and ethylene copolymer different from the first component.

18. The composition of claim 17 wherein the third component has a glass transition temperature higher than about 120° C. and the first component has a glass transition temperature of lower than about 120° C.

19. The composition of claim 18 wherein the third component is present in an amount from 10% to about 90% by weight of the composition.

20. The composition of claim 19 wherein the first component and second component are present in a ratio of from about 2:1 to about 1:2 by weight.

21. The composition of claim 13 wherein the glass transition temperature of the first component is from about 70° C. to about 130° C.

\* \* \* \* \*

UNITED STATES PATENT AND TRADEMARK OFFICE  
**CERTIFICATE OF CORRECTION**

PATENT NO. : 6,255,396 B1  
DATED : July 3, 2001  
INVENTOR(S) : Yuan-pang Samuel Ding et al.

Page 1 of 2

It is certified that error appears in the above-identified patent and that said Letters Patent is hereby corrected as shown below:

Title page,

Item [56], **References Cited**, U.S. PATENT DOCUMENTS, replace "5,698,654" with -- 5,698,645 --  
FOREIGN PATENT DOCUMENTS, "97/08054" replace "6/1997" with -- 3/1997 --, "98/27926" replace "2/1998" with -- 7/1998 --

Column 1,

Line 42, replace "PVC" with -- polyvinyl chloride --

Column 2,

Line 65, delete "a"

Column 3,

Lines 13, 22 and 29, replace "norbornene" with -- norbornene --

Column 4,

Line 23, insert -- , -- after "carbons"  
Line 29, replace "homopolymer" with -- homopolymers --  
Line 46, insert -- be -- after "can"  
Line 64, replace "tradeanme" with -- tradename --

Column 5,

Line 26, replace "components" with -- component --  
Line 36, replace "more" with -- most --  
Line 38, replace the first "and" with -- an --  
Line 58, replace "norbornene" with -- norbornene --

Column 7,

Line 41, insert -- " -- before "aliphatic"

Column 8,

Lines 19 and 20, replace "Mpa" with -- MPa --  
Line 36, replace "infusions" with -- infusion --

Column 9,

Lines 30, 31 and 55, replace "norbornene" with -- norbornene --

UNITED STATES PATENT AND TRADEMARK OFFICE  
**CERTIFICATE OF CORRECTION**

PATENT NO. : 6,255,396 B1  
DATED : July 3, 2001  
INVENTOR(S) : Yuan-pang Samuel Ding et al.

Page 2 of 2

It is certified that error appears in the above-identified patent and that said Letters Patent is hereby corrected as shown below:

Column 11,

Line 15, insert -- : -- after "EVA"  
Line 18, insert -- : -- after "Polybutene"  
Line 22, insert -- : -- after "copolymer"

Column 13,

Lines 26, 27, 28, 39, 40, 41, 42 and 53, replace "cyclo hexane" with -- cyclohexane --

Column 14,

Line 65, "talbe" with -- table --

Column 16,

Line 22, insert -- (wt %) -- beneath "Ratio"  
Line 60, replace "norbomene" with -- norbornene --

Column 17,

Line 26, replace "norbomene" with -- norbornene --

Column 18,

Line 18, replace "obtaining" with -- obtained --

Signed and Sealed this

Fifth Day of August, 2003

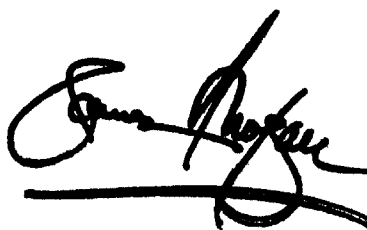

JAMES E. ROGAN  
*Director of the United States Patent and Trademark Office*